



INVERTER SERIES

V1000



EN

DE

ES

FR

IT

V1000
V1000
V1000

V1000

V1000

YASKAWA INVERTER DRIVE TECHNOLOGY

Contents

- ▶ **Page 2**
Experience & Innovation
A leader in Inverter Drives technology
V1000 – Easy and cost-saving handling through all kinds of applications
- ▶ **Page 3**
"One for all" – Multiple Applications
- ▶ **Page 4/5**
Specifications
- ▶ **Page 6**
Connection Diagram
- ▶ **Page 7**
V1000 Dimensions
- ▶ **Page 8**
V1000 Finless Version Dimensions
- ▶ **Page 9**
V1000 IP66 Dimensions
- ▶ **Page 10**
Options
- ▶ **Page 11**
Ratings & Type Descriptions incl. finless

Experience & Innovation

For more than 90 years YASKAWA has been manufacturing and supplying mechatronic products for machine building and industrial automation. Its standard products as well as tailor-made solutions are famous and have a high reputation for outstanding quality and durability.

A leader in Inverter Drives technology

Extensive research and development has allowed YASKAWA to remain at the forefront of motion control and automation technology. This technological leadership has helped to modernise industries such as mining, steel, pulp and paper, chemical, automotive, packaging, machine tool and semiconductor.

In 2007 YASKAWA produced its 10 millionth inverter in the new inverter plant in Yukuhashi, Japan. By this YASKAWA is probably the biggest inverter manufacturer in the world.

The 10 millionth inverter was a V1000, the latest inverter developed by YASKAWA. Awarded by IEN magazine as being the 'most innovative product 2007' at Hanover Fair Industry 2007 the V1000 has raised the bar in the market in terms of usability and reliability.

V1000 – Easy and cost-saving handling through all kinds of applications

This powerful little helper sets standards in terms of user friendliness and process orientation. The development of the V1000

focuses on all aspects of application, installation, operation and maintenance.

Safety Integrated

YASKAWA V1000 is one of the first general purpose compact drives with built-in two channel hardware base block input. It already meets international safety standards and thereby supports machine builder to apply to international machine directives.

Finless Type

YASKAWA has as one of the first manufacturers promoted the development of finless type inverters for the European and international markets. Consequently the V1000 is available as finless version for applications with an external cooling system.

YASKAWA V1000 Features

- ▶ Dual Safety Input, safety category 3 (EN954-1) and stop category 0 (EN60204-1) and IEC-61508 SIL2
- ▶ In normal duty (120% overload) one frame size larger motor can be driven
- ▶ Standard AC Motor and PM motor control
- ▶ V/f and open-loop current vector control
- ▶ One of the smallest inverter drives in the world
- ▶ Side-by-side mounting
- ▶ Icon-based programming
- ▶ Designed for 10 years of maintenance-free operation



“One for all” – Multiple Applications

YASKAWA V1000 is a general purpose inverter drive covering the demands of a wide field of applications. Simple duties as well as requirements of complex systems need a higher level of functionality, reliability and easy handling, which are provided by the V1000.

- ▶ For energy saving, permanent magnet motor control is possible
- ▶ Selectable control method: open-loop current vector or V/f
- ▶ Small Design – Big Power: 150% overload in heavy duty service is possible. For applications with low overload requirements the drive can be operated with 120% overload in normal duty service. Consequently you can use a drive of smaller size to do the work of a bigger one.
- ▶ Worldwide specification CE, UL, cUL, RoHS (TÜV safety approved)
- ▶ High flux braking reduces braking time to the half

Easy Installation

YASKAWA V1000 reduces installation time and costs. Installable in tight spaces it requires a minimum of set-up time and provides you all the comfort of a modern up-to-date inverter drive.

- ▶ One of the smallest inverter drives in the world saves mounting space and cost by side-by-side mounting
- ▶ Application parameter pre-settings shorten set-up time
- ▶ Same handling and parameter structure for all YASKAWA inverters
- ▶ DriveWorksEZ visual programming tool. Simply drag and drop icons to customize your drive. Create special sequences and detection functions, then load them onto the drive.

Reliable Operation

The V1000 continues the tradition of YASKAWA by being the reliable link in your production chain.

- ▶ Designed for Long Performance Life (10 years 24 h per day at 80% nominal load.)
- ▶ Quick response on load and speed changes improves your machine performance
- ▶ Online Auto-Tuning to optimise for improved motor performance at low speed
- ▶ Optional external 24 VDC-supply assures communication and data flow in any power-down situation
- ▶ Dual safety input: safety category 3 (EN954-1), stop category 0 and IEC-61508 SIL2

Quick Maintenance

YASKAWA V1000 is an inverter drive which adapts to user demands and provides maintenance functions that ensure quick replacement and minimize down time.

- ▶ Removable terminal board with parameter memory for quick and easy maintenance
- ▶ Screwless control terminal saves setup time





Specifications

Voltage class		Single-phase 200 V						
Inverter model CIMR-VCBA* ¹		0001	0002	0003	0006	0010	0012	00018* ⁶
Inverter output	Motor output kW at normal duty* ²	0.18	0.37	0.75	1.1	2.2	3.0	-
	Motor output kW at heavy duty* ²	0.1	0.18	0.55	0.75	1.5	2.2	4.0
	Rated output current at normal duty [A]* ³	1.2	1.9	3.3	6	9.6	12	-
	Rated output current at heavy duty [A]	0.8* ⁴	1.6* ⁴	3.0* ⁴	5.0* ⁴	8.0* ⁵	11.0* ⁵	17.5* ⁵
	Overload	125% for 60 sec normal duty, 150 % for 60 sec at heavy duty from inverter rated output current						
	Rated output power at normal duty [kVA]*	0.5	0.7	1.3	2.3	3.7	4.6	-
	Rated output power at heavy duty [kVA]*	0.3	0.6	1.1	1.9	3.0	4.2	6.7
	Max. output voltage	Three-phase 200 to 240 V (proportional to input voltage)						
Max. output frequency	400 Hz							
Inverter input	Rated input voltage	Single-phase 200 to 240 V, -15% to +10%						
	Rated input frequency	50/60 Hz, ±5%						

* based on input voltage 220 V

Voltage class		Three-phase 200 V										
Inverter model CIMR-VC2A		0001	0002	0004	0006	0010	0012	0020	0030	0040	0056	0069
Inverter output	Motor output kW at normal duty* ²	0.18	0.37	0.75	1.1	2.2	3.0	5.5	7.5	11.0	15.0	18.5
	Motor output kW at heavy duty* ²	0.1	0.2	0.4	0.75	1.5	2.2	4.0	5.5	7.5	11.0	15.0
	Rated output current at normal duty [A]* ³	1.2	1.9	3.5	6.0	9.6	12.0	19.6	30.0	40.0	56.0	69.0
	Rated output current at heavy duty [A]	0.8* ⁴	1.6* ⁴	3.0* ⁴	5.0* ⁴	8.0* ⁵	11.0* ⁵	17.5* ⁵	25.0* ⁵	33.0* ⁵	47.0* ⁵	60.0* ⁵
	Overload	120% for 60 sec at normal duty, 150% for 60 sec at heavy duty from inverter rated output current										
	Rated output power at normal duty [kVA]*	0.5	0.7	1.3	2.3	3.7	4.6	7.5	11.4	15.2	21.3	26.3
	Rated output power at heavy duty [kVA]*	0.3	0.6	1.1	1.9	3.0	4.2	6.7	9.5	12.6	17.9	22.9
	Max. output voltage	Three-phase 200 to 240 V (proportional to input voltage)										
Max. output frequency	400 Hz											
Inverter input	Rated input voltage	Three-phase 200 to 240 V, -15% to +10%										
	Rated input frequency	50/60 Hz, ±5%										

* based on input voltage 220V

Voltage class		Three-phase 400 V										
Inverter model CIMR-VC4A		0001	0002	0004	0005	0007	0009	0011	0018	0023	0031	0038
Inverter output	Motor output kW at normal duty* ²	0.37	0.75	1.5	2.2	3.0	4.0	5.5	7.5	11	15.0	18.5
	Motor output kW at heavy duty* ²	0.18	0.37	0.75	1.5	2.2	3.0	4.0	5.5	7.5	11.0	15.0
	Rated output current at normal duty [A]* ³	1.2	2.1	4.1	5.4	6.9	8.8	11.1	17.5	23.0	31.0	38.0
	Rated output current at heavy duty [A]* ⁵	1.2	1.8	3.4	4.8	5.5	7.2	9.2	14.8	18.0	24.0	31.0
	Overload	120% for 60 sec at normal duty, 150% for 60 sec at heavy duty from inverter rated output current										
	Rated output power at normal duty [kVA]*	0.9	1.6	3.1	4.1	5.3	6.7	8.5	13.3	17.5	23.6	29.0
	Rated output power at heavy duty [kVA]*	0.9	1.4	2.6	3.7	4.2	5.5	7.0	11.3	13.7	18.3	23.6
	Max. output voltage	Three-phase 380 to 480 V (proportional to input voltage)										
Max. output frequency	400 Hz											
Inverter input	Rated input voltage	Three-phase 380 to 480 V, -15% to +10%										
	Rated input frequency	50/60 Hz, ±5%										

* based on input voltage 400 V

¹ Drives with a single-phase power supply input have three-phase output. Single-phase motors cannot be used.

² The motor capacity (kW) refers to a YASKAWA 4-pole, 60 Hz, 200 V motor. The rated output current of the drive output amps should be equal to or greater than the motor rated current.

³ at 2 kHz carrier frequency without derating

⁴ at 10 kHz carrier frequency without derating

⁵ at 8 kHz carrier frequency without derating

⁶ only heavy duty available



Rotational Auto-Tuning must be performed to achieve the performance described with Open Loop Vector Control.

		Specifications
Control Functions	Control methods	Open Loop Vector Control (Current Vector), V/f Control, PM Open Loop Vector Control (for SPM and IPM motors)
	Frequency Control Range	0.01 to 400 Hz
	Frequency Accuracy (Temperature Fluctuation)	Digital input: within $\pm 0.01\%$ of the max. output frequency (-10°C to $+50^{\circ}\text{C}$) Analog input: within $\pm 0.1\%$ of the max. output frequency ($25^{\circ}\text{C} \pm 10^{\circ}\text{C}$)
	Frequency Setting Resolution	Digital input: 0.01 Hz Analog input: 1/1000 of max. frequency
	Output Frequency Resolution	20 bit of maximum output frequency (parameter E1-04 setting)
	Frequency Setting Resolution	Main frequency reference: 0..10 V (20 k Ω) 10 bit, 4..20 mA (250 Ω) or 0..20 mA (250 Ω) 9-bit Main speed reference : Pulse Train Input (max. 32 kHz)
	Starting Torque	200% / 0.5 Hz (assumes Heavy Duty rating AC Motor of 3.7 kW or less using Open Loop Vector Control), 50% / 6 Hz (assumes PM Open Loop Vector Control)
	Speed Control Range	1:100 (Open Loop Vector Control), 1:20 to 40 (V/f Control), 1:10 (PM Open Loop Vector Control)
	Speed Control Accuracy	$\pm 0.2\%$ in Open Loop Vector Control ($25^{\circ}\text{C} \pm 10^{\circ}\text{C}$) *1
	Speed Response	5 Hz in Open Loop Vector ($25^{\circ}\text{C} \pm 10^{\circ}\text{C}$) (requires Rotational Auto-Tuning)
	Torque Limit	Open Loop Vector Control allows separate settings in four quadrants
	Accel/Decel Time	0.0 to 6000.0 s (4 selectable combinations of independent acceleration and deceleration settings)
	Braking Torque	① Short-time decel torque*2: over 150% for 0.1/0.2 kW motors, over 100% for 0.4/ 0.75 kW motors, over 50% for 1.5 kW motors, and over 20% for 2.2 kW and above motors (overexcitation braking/High-Slip Braking: approx. 40%) ② Continuous regen. torque: approx. 20% (approx. 125% with dynamic braking resistor option*3: 10% ED, 10 s, internal braking transistor)
	V/f Characteristics	User-selected programs, V/f preset patterns possible
Main Control Functions	Momentary power loss ride-thru, Speed search, Overtorque detection, Torque limit, 17-step speed (max), Accel/decel time switch, S-curve accel/dec, 3-wire sequence, Auto-tuning (rotational, stationary tuning for resistance between lines), Dwell, Cooling fan on/off switch, Slip compensation, Torque compensation, Frequency jump, Upper/lower limits for frequency reference, DC injection braking at start and stop, Overexcitation braking, High slip braking, PID control (with sleep function), Energy saving control, MEMOBUS comm. (RS-485/422 max, 115.2 kbps), Fault restart, Application presets, DriveWorksEZ (customized function), Removable terminal block with parameter backup function...	
Protection Function	Motor Protection	Motor overheat protection based on output current
	Momentary Overcurrent Protection	Drive stops when output current exceeds 200% of Heavy Duty Rating
	Overload Protection	Drive stops after 60 s at 150% of rated output current (Heavy Duty Rating)*4
	Overvoltage Protection	200 V class: Stops when DC bus exceeds approx. 410 V 400 V class: Stops when DC bus exceeds approx. 820 V
	Undervoltage Protection	Stops when DC bus voltage falls below the following levels: Three-phase 200 V class: approx. 190 V, single-phase 200 V class: approx. 160 V, three-phase 400 V class: approx. 380 V, three-phase 380 V class: approx. 350 V
	Momentary Power Loss Ride-Thru	Stops after approx. 15 ms (default). Parameter settings allow the drive to continue running if power loss lasts for up to approx. 2 s *5
	Heatsink Overheat Protection	Protection by thermistor
	Braking Resistance Overheat Protection	Overheat sensor for braking resistor (optional ERF-type, 3% ED)
	Stall Prevention	Separate settings allowed during acceleration, and during run. Enable/disable only during deceleration.
Operating Environment	Ground Fault Protection	Protection by electronic circuit *6
	Charge LED	Charge LED remains lit until DC bus has fallen below approx. 50 V
	Area of Use	Indoors
	Ambient Temperature	-10°C to $+50^{\circ}\text{C}$ (open chassis), -10°C to $+40^{\circ}\text{C}$ (NEMA Type 1)
	Humidity	95 RH% or less (no condensation)
	Storage Temperature	-20°C to $+60^{\circ}\text{C}$ (short-term temperature during transportation)
	Altitude	Max. 1000 m (output derating of 1% per 100 m above 1000 m, max. 3000 m)
Shock	10 to less than 20 Hz (9.8 m/s ²) max., 20 to 55 Hz (5.9 m/s ²) max.	
Safety Standard	UL508C, EN954-1 Cat. 3, IEC/EN61508 SIL2	
Protection Design	IP20 open-chassis, NEMA Type 1 enclosure	

*1 Speed control accuracy may vary slightly depending on installation conditions or motor used.

*2 Momentary average deceleration torque refers to the deceleration torque from 60Hz down to 0 Hz. This may vary depending on the motor.

*3 If L3-04 is enabled when using a braking resistor or braking resistor unit, the motor may not stop within the specified deceleration time.

*4 Overload protection may be triggered at lower levels if output frequency is below 6 Hz.

*5 Varies by drive capacity. Drives smaller than 7.5 kW (CIMR-VA2A0004/CIMR-VA4A0023) require a separate Momentary Power Loss Recovery Unit to continue operating during a momentary power loss of 2 s.

*6 Protection may not be provided under the following conditions as the motor windings are grounded internally during run:

- Low resistance to ground from the motor cable or terminal block.
- Drive already has a short-circuit when the power is turned on.



Connection Diagram

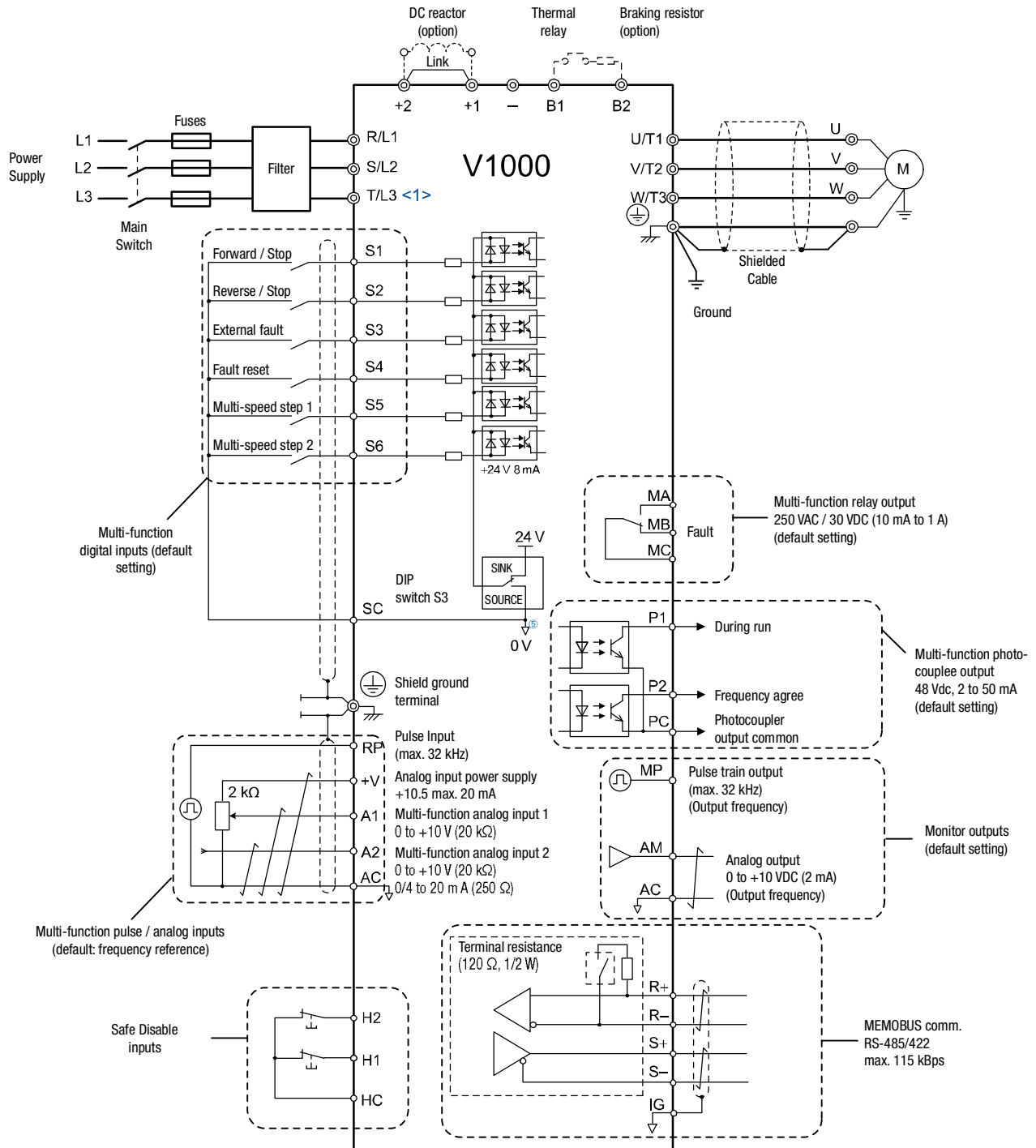

- ⊕ Use twisted pair cables.
- ⊕ Use shielded twisted pair cables.
- ⊙ Indicates a main circuit terminal.
- Indicates a control circuit terminal.



V1000 Dimensions

IP20/Open-Chassis (without an EMC filter)

Voltage Class	Drive Model CIMR-VC□	Dimensions in mm									Weight (kg)
		W1	H1	W	H	D	t1	H2	D1		
Single-Phase 200 V Class	BA0001B	56	118	68	128	76	3	5	5	6.5	0.6
	BA0002B					118	5			38.5	1.0
	BA0003B					118	5			38.5	1.0
Three-Phase 200 V Class	2A0001B	56	118	68	128	76	3	5	5	6.5	0.6
	2A0002B					118	5			38.5	0.9
	2A0004B					118	5			38.5	0.9
	2A0006B					118	5			58.5	1.1

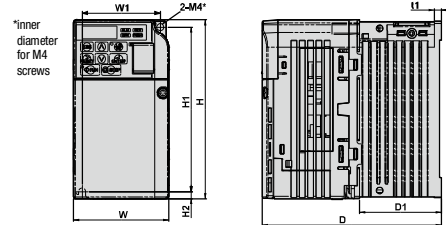

Voltage Class	Drive Model CIMR-VC□	Dimensions in mm									Weight (kg)
		W1	H1	W	H	D	t1	H2	D1		
Single-Phase 200 V Class	BA0006B	128	118	140	128	137.5	5	5	5	58	1.7
	BA0010B					154				1.8	
	BA0012B					163				2.4	
	BA0018B					170				3.0	
Three-Phase 200 V Class	2A0010B	96	118	108	128	129	5	5	5	58	1.7
	2A0012B					137.5				2.4	
	2A0020B					143				2.4	
Three-Phase 400 V Class	4A0001B	96	118	108	128	81	5	5	5	10	1.0
	4A0002B					99				1.2	
	4A0004B					137.5				1.7	
	4A0005B					137.5				1.7	
	4A0007B					154				1.7	
	4A0009B					154				1.7	
	4A0011B					143				2.4	
	4A0011B					128				140	143

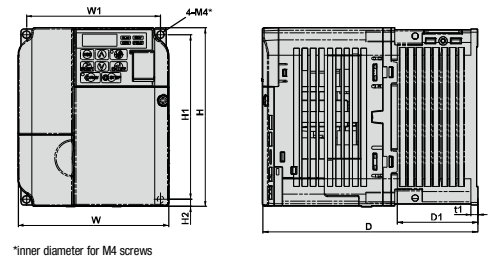

IP20/NEMA Type 1 (without an EMC filter)

Voltage Class	Drive Model CIMR-VC□	Dimensions in mm													Weight (kg)
		W1	H2	W	H1	D	t1	H5	D1	H	H4	H3	H6		
Single-Phase 200 V Class	BA0001F	56	118	68	128	76	3	5	6.5	149.5	20	4	1.5	0.8	
	BA0002F					118	5	39	1.2						
	BA0003F					118	5	39	1.2						
Three-Phase 200 V Class	2A0001F	56	118	68	128	76	3	5	6.5	149.5	20	4	1.5	0.8	
	2A0002F					118	5	39	1.1						
	2A0004F					118	5	39	1.1						
	2A0006F					128	5	59	1.3						

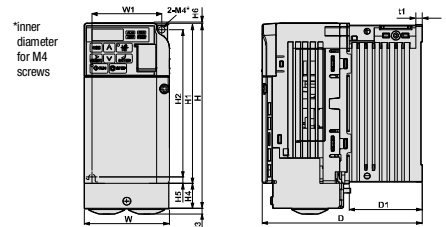

Voltage Class	Drive Model CIMR-VC□	Dimensions in mm													Weight (kg)
		W1	H2	W	H1	D	t1	H5	D1	H	H4	H3	H6		
Single-Phase 200 V Class	BA0006F	128	118	140	128	137.5	5	5	5	58	149.5	20	4	1.5	1.9
	BA0010F					154				2.0					
	BA0012F					163				2.6					
	BA0018F					170				3.3					
Three-Phase 200 V Class	2A0010F	96	118	108	128	129	5	5	5	58	149.5	20	4	1.5	1.9
	2A0012F					137.5				2.6					
	2A0020F					143				2.6					
Three-Phase 400 V Class	4A0001F	96	118	108	128	81	5	5	5	10	149.5	20	4	1.5	1.2
	4A0002F					99				1.4					
	4A0004F					137.5				1.9					
	4A0005F					137.5				1.9					
	4A0007F					154				1.9					
	4A0009F					154				1.9					
	4A0011F					143				2.6					

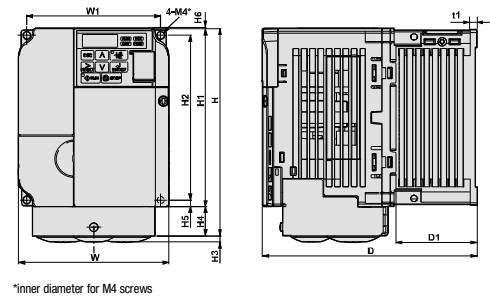

Voltage Class	Drive Model CIMR-VC□	Dimensions in mm													Weight (kg)		
		W1	H2	W	H1	D	t1	H5	D1	H	H4	H3	H6	d			
Three-Phase 200 V Class	2A0030F	122	248	140	234	140	5	13	55	254	13	6	1.5	M5	3.8		
	2A0040F													75	290	15	5.5
	2A0056F													78	350	15	9.2
	2A0069F													78	350	15	9.2
Three-Phase 400 V Class	4A0018F	122	248	140	234	140	5	13	55	254	13	6	1.5	M5	3.8		
	4A0023F													75	290	15	5.2
	4A0031F													75	290	15	5.5
	4A0038F													75	290	15	5.5

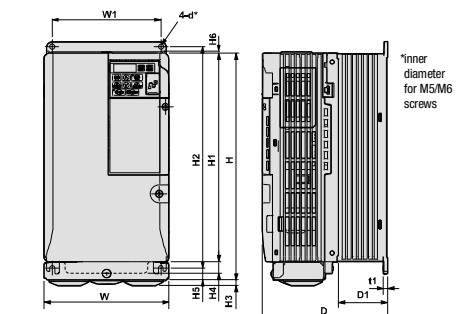

Ratings & Type Descriptions

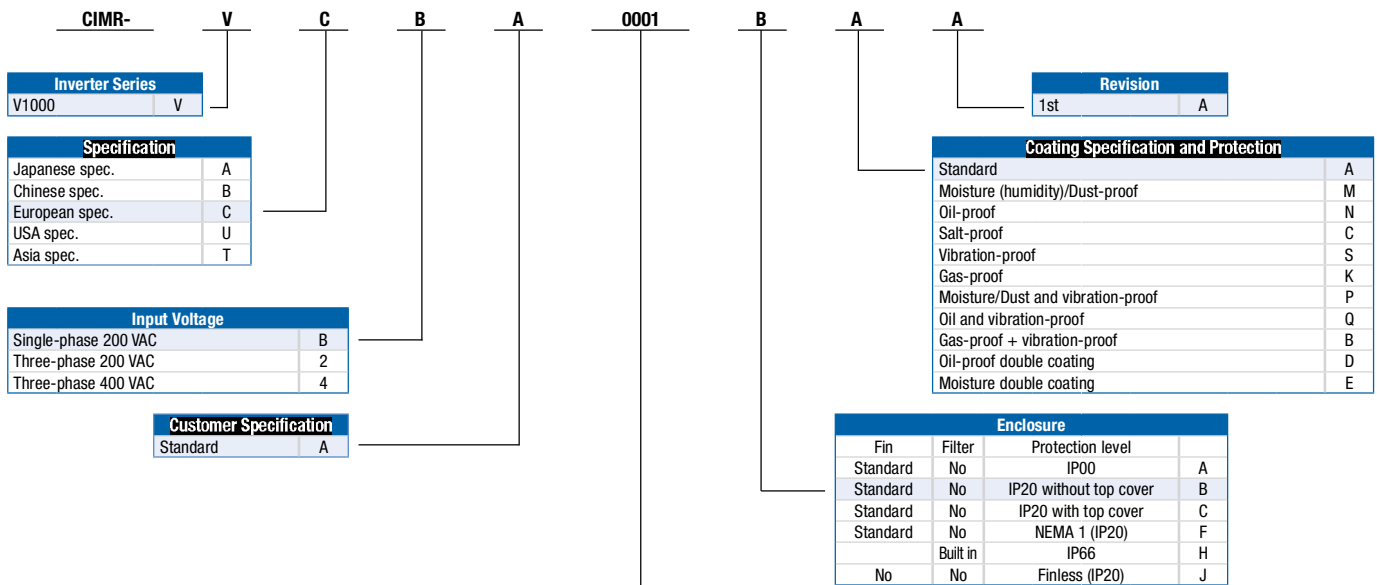

Single-phase 200 VAC				
	Normal duty		Heavy duty	
	Rated output current	Max. applicable motor	Rated output current	Max. applicable motor
0001	1.2 A	0.18 kW	0.8 A	0.1 kW
0002	1.9 A	0.37 kW	1.6 A	0.18 kW
0003	3.3 A	0.75 kW	3.0 A	0.55 kW
0006	6.0 A	1.1 kW	5.0 A	0.75 kW
0010	9.6 A	2.2 kW	8.0 A	1.5 kW
0012	12.0 A	3.0 kW	11.0 A	2.2 kW
0018	-	-	17.5 A	4.0 kW

Three-phase 200 VAC				
	Normal duty		Heavy duty	
	Rated output current	Max. applicable motor	Rated output current	Max. applicable motor
0001	1.2 A	0.4 kW	0.8 A	0.1 kW
0002	1.9 A	0.37 kW	1.6 A	0.2 kW
0004	3.5 A	0.75 kW	3.0 A	0.4 kW
0006	6.0 A	1.1 kW	5.0 A	0.75 kW
0010	9.6 A	2.2 kW	8.0 A	1.5 kW
0012	12.0 A	3.0 kW	11.0 A	2.2 kW
0020	19.6 A	5.5 kW	17.5 A	4.0 kW
0030	30.0 A	7.5 kW	25.0 A	5.5 kW
0040	40.0 A	11.0 kW	33.0 A	7.5 kW
0056	56.0 A	15.0 kW	47.0 A	11.0 kW
0069	69.0 A	18.5 kW	60.0 A	15.0 kW

Three-phase 400 VAC				
	Normal duty		Heavy duty	
	Rated output current	Max. applicable motor	Rated output current	Max. applicable motor
0001	1.2 A	0.37 kW	1.2 A	0.2 kW
0002	2.1 A	0.75 kW	1.8 A	0.4 kW
0004	4.1 A	1.5 kW	3.4 A	0.75 kW
0005	5.4 A	2.2 kW	4.8 A	1.5 kW
0007	6.9 A	3.0 kW	5.5 A	2.2 kW
0009	8.8 A	4.0 kW	7.2 A	3.0 kW
0011	11.1 A	5.5 kW	9.2 A	4.0 kW
0018	17.5 A	7.5 kW	14.8 A	5.5 kW
0023	23.0 A	11.0 kW	18.0 A	7.5 kW
0031	31.0 A	15.0 kW	24.0 A	11.0 kW
0038	38.0 A	18.5 kW	31.0 A	15.0 kW